

mwalimuepublishers@gmail.com

FORM 2 SET 3 EXAMS

ALL SUBJECTS

Attempt these exams!

FOR MARKING SCHEMES CALL
0705525657 / 0770195807

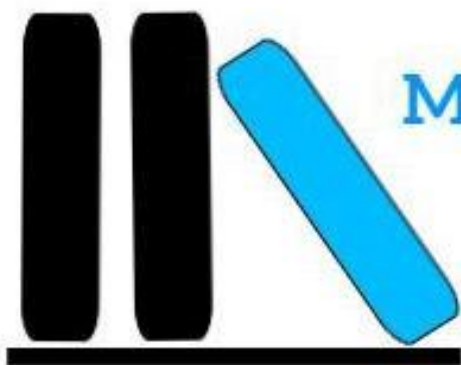

Mwalimu E-Publishers

 0705525657 / 0770195807

Home Of Quality E-resources

FOR MORE RESOURCES CALL 0705 525657

FORM TWO SET 3 EXAMS 2020

NAME.....ADM. NO.....CLASS.....

**TERM 2 EXAM
FORM 2 MATHEMATICS**

TIME: 2½ HRS.

INSTRUCTION TO STUDENTS:

1. Write your **name**, **admission number** and **class** in the spaces provided above.
2. Write the **date** of examination in spaces provided.
3. This paper consists of **two** Sections; Section **I** and Section **II**.
4. Answer **ALL** the questions in Section **I** and only **five** questions from Section **II**.
5. All answers and working must be written on the question paper in the spaces provided below each question.
6. Show all the steps in your calculation, giving your answer at each stage in the spaces provided **below** each question.
7. Marks may be given for correct working even if the answer is wrong.
8. KNEC Mathematical tables **may be** used, except where stated otherwise.
9. Candidates should check the question paper to ascertain that all the pages are printed as indicated and that no questions are missing.
10. Candidates should answer the questions in **English**.

FOR EXAMINER'S USE ONLY:

SECTION I

1	2	3	4	5	6	7	8	9	10	11	12	13	14	15	16	TOTAL

SECTION II

GRAND TOTAL

For more Eresources Call: 0705 525657

5. The diagram below represents a prism of length 6cm whose cross-section is an equilateral triangle of sides 3cm. Draw a well labeled sketch of the net of the prism. (3 Marks)

6. The figure below represents a kite ABCD, $AB = AD = 15$ cm. The diagonals BD and AC intersect at O. $AC = 30$ cm and $AO = 12$ cm.

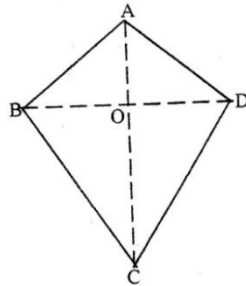

Find the area of the kite (3mks)

7. Mrs. Kangogo has Sh. 700 in Sh. 50 notes and Sh. 100 notes only. If she has a total of 11 notes find how many notes she has of each denomination. (3mks)

8. In the figure below $AD \parallel BC$. AC and BD intersect at E. Given that $AE: EC = 1:5$ and $BD = 12$ cm, calculate the length of DE.

A

D

E

B

C

(3 marks)

9. Given that $\sin(x + 60)^\circ = \cos(2x)$, find $\tan(x + 60)^\circ$ (3marks)

10. A salesman gets a commission of 2.4% on sales up to Sh. 100,000. He gets additional commission of 1.5% on sales above this. Calculate the commission he gets for sales worth Sh. 280,000. (3 Marks)

11. In the figure below, lines AB and LM are parallel.

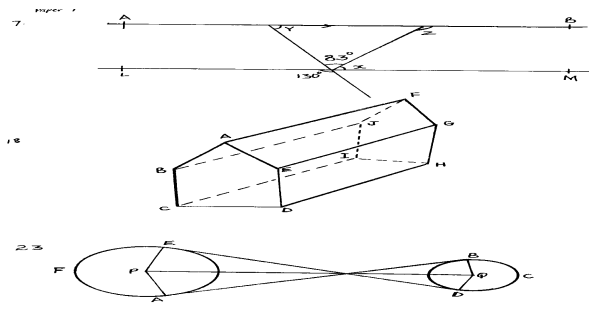

Find the values of the angles marked x, y and z.

(3mks)

12. The surface areas of two similar bottles are 12cm^2 and 108cm^2 respectively. If the bigger one has a volume of 810cm^3 . Find the volume of the smaller one. (3 Marks)

13. In the figure below, triangle A'B'C' is the image of triangle ABC under a rotation, centre O.

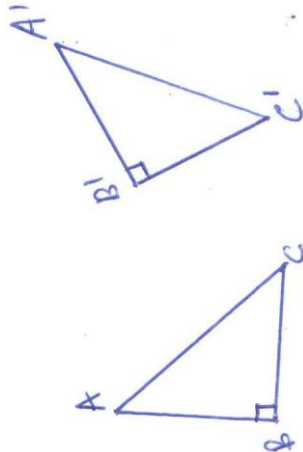

By construction, find and label the centre O of the rotation. Hence, determine the angle of the rotation.(3mks)

14. In the figure below triangle ABO represents a part of a school badge. The badge has as symmetry of order 4 about O. Complete the figure to show the badge. (3mks)

For more Eresources Call: 0705 525657

15. A rectangular tank of base 2.4 m by 2.8 m and a height of 3 m contain 3,600 liters of water initially. Water flows into the tank at the rate of 0.5 litres per second. Calculate the time in hours and minutes, required to fill the tank (4 marks)

16. The exterior angle of a regular polygon is equal to one-third of the interior angle. Calculate the number of sides of the polygon and give its name. (4mks)

SECTION II (50MKS)

Answer 5 questions only in this section

17. The vertices of quadrilateral OPQR are O (0, 0), P (2, 0), Q (4, 2) and R (0, 3). The vertices of its image under a rotation are O' (1, -1), P'(1, -3) Q'(3, -5) an R'(4, -1).

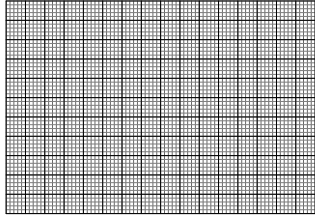

- (a) (i) On the grid provided, draw OPQR and its image O'P'Q'R' (2marks)
- (b) (ii) By construction, determine the centre and angle of rotation. (3marks)
- (c) On the same grid as (a) (i) above, draw O''P''Q''R'', the image of O'P'Q'R' under a reflection in the line $y = x$ (3marks)
- (d) From the quadrilaterals drawn, state the pairs that are:
- (i) Directly congruent; (2marks)
- (ii) Oppositely congruent (2marks)

18. A slaughter house bought a number of goats at Sh. 2000 each and a number of bulls at Sh. 15000 each. They paid a total of Sh. 190,000. If they bought twice as many goats and three bulls less, they would have saved Sh. 5000.

(a) Find the number of each type of animals bought. (6 Marks)

(b) The slaughter house sold all the animals at a profit of 25% per goat and 30% per bull. Determine the total profit they made. (4 Marks)

19. a) In a safari rally drivers are to follow route ABCDA. B is 250km from A on a bearing of 075° from A. C is on a bearing of 110° from A and 280km from B. The bearing of C from D is 040° and a distance of 300km. By scale drawing show the position of the point A, B, C and D. (4mks)

b) Determine

(i) The distance of A from C. (2mks)

(ii) The bearing of B from C. (1mk)

(iii) The distance and bearing of A from D. (3mks)

20. A saleswoman is paid a commission of 20% on goods sold worth over Ksh 100,000. She is also paid a monthly salary of Ksh 12,000. In a certain month, she sold 360 handbags at Ksh 500 each.

(i) Calculate the saleswoman's earnings that month. (3 mks)

The following month, the saleswoman's monthly salary was increased by 10%. Her total earnings that month were Ksh17,600.

Calculate:

(ii) The total amount of money received from the sales of handbags that month. (5mks)

(iii) The number of handbags sold that month. (2 mks)

21. Using a ruler and a pair of compasses only, draw a parallelogram ABCD, such that angle DAB = 75° . Length AB = 6.0cm and BC = 4.0cm from point D, drop a perpendicular to meet line AB at N. (7 Marks)

(i) Measure length DN. (1 Mark)

(ii) Find the area of the parallelogram. (2 Marks)

22. United Millers imports wheat from U.S.A at initial cost of 350 dollar per tone. The shipping costs and customs duty are then charged as 25% and 15% respectively. When the wheat reached Mombasa, an 8% of the initial cost is incurred to transport it to Kisumu.

(a) Given that 1US dollar = Ksh82.40, calculate the total cost of importing 5 tonnes of wheat in Ksh. (5 marks)

(b) The united millers intend to make a profit of 25%. Giving your answer to the nearest ten cents, calculate the price at which a 2 kg packet of wheat should be sold. (3 marks)

c. How much profit shall the company realize from the sale of 1 tonne of wheat? (2 marks)



23.

The diagram shows vertical telephone pole RS supported by wires SP and SQ pegged at points P and Q respectively on a level ground. Points P and Q are on the same straight line from the base R of the pole. The angles of elevation of S from P and Q are 33.9° and 48.2° respectively. Given that $PR = 5$ m, calculate:

(a) The distance QR (4 marks)

(b) The length of the wires SP and SQ

(4 marks)

(c) If the cost of the pole and labour is sh. 1600 and the cost of 1 meter of the wire is sh. 233.

Find the total cost of the installation.

(2 marks)

24. a) Construct the image of quadrilateral ABCD under enlargement scale factor -2 center of enlargement E. (4mks)



b) A model of a freezer has a rectangular shutter measuring 4cm by 2cm. The area of the actual shutter of the freezer is 0.72m^2 .

i) Given that the actual freezer is 2.7m long, calculate the length of the model in centimeters. (3mks)

ii) Calculate the volume in m^3 of the actual freezer if the models volume is 12cm^3 (3mks)

mwalimuepublishers@gmail.com

FORM TWO SET 3 EXAMS 2020

NAME.....CLASS.....ADM.....

FORM 2 AGRICULTURE EXAM

TIME .2HRS

INSTRUCTIONS

ANSWER ALL THE QUESTIONS IN SECTION A,B,C.

ALL ANSWERS MUST BE WRITTEN IN THE SPACES PROVIDED.

For more Eresources Call: 0705 525657

SECTION A (30MKS)

1. What is Health (1mk)

2. State 4 symptoms of potassium deficiency in crops.(2mks)

3. State the information contained in a composite sample of soil before being taken to the laboratory. (1½mks.)

4. Give 4 disadvantages of using vegetative propagation materials.(2mks)

5. Given that maize is planted at a spacing of 75 by 25 cm. calculate the plant population in a plot of land measuring 8 by 6m. (3mks)

6. Differentiate between monocropping and intercropping (1mk)

7. Define the following terms as used in agriculture
Rogueing (1mk)

Gapping (1mk)

8. State any four disadvantages of using non capped multiple stem pruning in coffee.(2mks)
9. Give 4 characteristics of a good grain store.(2mks)
10. 10. State the intermediate host of the following livestock parasite.
- (a) Taenia solium ½mk
- (b) Taenia sagnata ½mk
- (c) Liver fluke ½mk
11. Give 4 control measures of Tse tse flies.(2mks)
12. State disadvantages of overhead irrigation.(2mks)
13. State the uses of the following farm tools and equipment
- (a) Dibber(1mk)

(b) Garden trowel (1mk)

(c) Stock and die (1mk)

(d) Pipe wrench (1mk)

14. State the function of the following materials in preparation of compost manure.

(a) Well rotten manure (1mk)

(b) Wood ash (1mk)

(c) Top soil (1mk)

15. Differentiate between Essex saddleback and Wessex saddleback.(1mk)

SECTION B (30MKS)

16. The diagram below shows a method of soil sampling

For more Eresources Call: 0705 525657

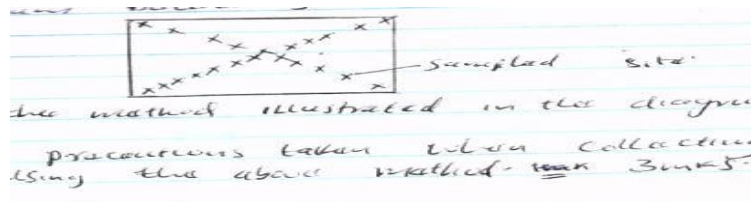

(a) Name the method illustrated in the diagram above.(1mk)

(b) State 3 precautions taken when collecting the soil for testing using the above method.(3mks)

(c) Give 4 reasons why soil from the farm is tested.(4mks)

17. The diagram below shows a practice carried out on various crops on the farm. Study them carefully and answer the questions that follow.

For more Eresources Call: 0705 525657

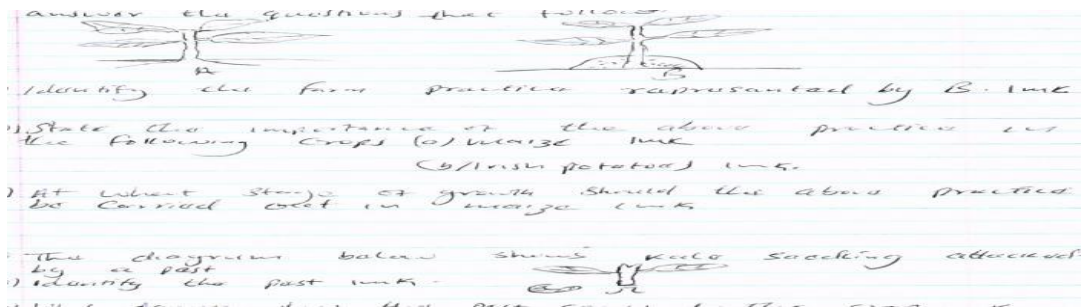

(a) Identify the farm practice represented by B. (1mk)

(b) State the importance of the above practice in the following crops

a) Maize (1mk)

b) Irish potatoes (1mk)

(c) At what stage of growth should the above practice be carried out in maize. (1mk)

18. The diagram below shows Kale seedling attached by a pest.



(a) Identify the pest. (1mk)

(b) What damage does that pest causes to the crop.1(1mk)

(c) State two methods of controlling the pest.(2mks)

19. State any 5 general characteristics of indigenous breed of cattle.(5mks)

20. State any 5 factors considered when selecting a nursery site.(5mks)

21. State conditions that necessitate land clearing (4mks)

SECTION C(40mks)

22.a) State and explain 5 characteristics of a fertile soil (10mks)

b) State symptoms of attack by a liver flukes in livestock.(5mks)

c) describe any five factors influencing crop rotation.(5mks)

23. Describe reasons for pruning in crops. 5x 2=10mks.

b)discuss 5 effects of HIV/AIDS and ill-health on Agriculture.(5mks)

c) discuss 5 problems associated with the use of organic manure.(5mks)

FORM TWO SET 3 EXAMS 2020

FORM II BIOLOGY

NAME: ADM NO:

SECTION A

1. Study the diagram below

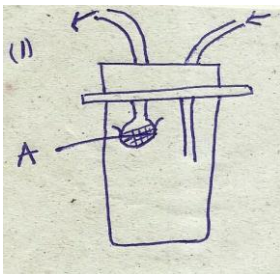

- a) Name the apparatus (1mk)
- b) Suggest the use of the apparatus. (1mk)
- c) Name the part labeled A and state its function. (2mks)

2. Name the field of biology that specializes in the study of the following; (3mks)
- i. Insects
 - ii. Interrelationships between organism and their environment.
 - iii. Heredity and variations.

3. The structure below was observed under the light microscope.

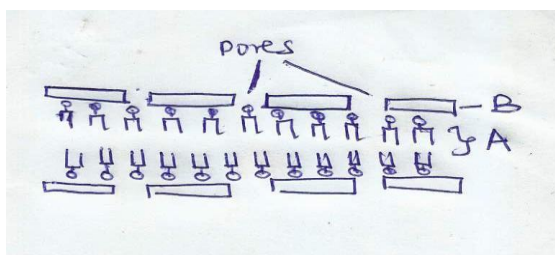

I: 0705 525657

- a) Identify the cell structure.
(1mk)
- b) Name the parts labeled A and B
(2mks)
- c) State two functions of the above structure.
(2mks)

4. The diagram below shows a certain cell in living organisms.

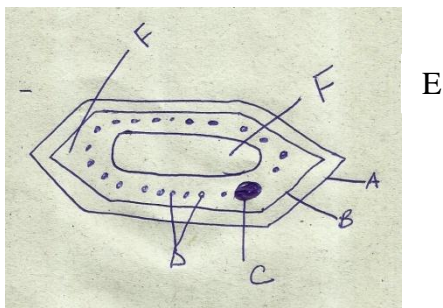

- a)
 - i. Identify the cell
(1mk)
 - ii. Give two reasons for your answer
(2mks)

b) Name the parts labeled;
(3mks)

A	D.....
B	E.....
C	F.....

- c) State the functions of the parts labeled C, D and E.
(3mks)

C.....

D.....

E.....

- 5. Name the organelles in a cell which perform the following functions. (3mks)

- i. Excretion in Amoeba
- ii. Secretion of synthesized proteins and carbohydrates.
- iii. Formation of cilia and flagella.

- 6. The diagram below represents a cross section of a plant part.

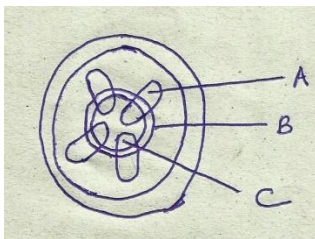

- i. From which part of the plant was the section obtained?
(1mk)
- ii. Name the parts labeled A,B and C.
(3mks)

A..... B..... C.....

- iii. What is the function of the part labeled C?
(2mks)

- 7.

- i. What is transpiration?
(1mk)

For more Eresources Call: 0705 525657

- ii. Give two importance of transpiration in plants
(2mks)

- iii. Name two sites for transpiration
(2mks)

- iv. Name the instrument which is used to determine transpiration rate.
(1mk)

8. Name the :
(2mks)

- a) Material that strengthens the xylem tissue
- b) Tissue that is removed when the bark of a dicotyledonous plant is ringed.

9. Name the blood vessel that transports blood from;
(2mks)

- a. Lungs to the heart

- b. The aorta to the liver

SECTION B 40 MARKS

10. The diagram below illustrates blood circulation in certain organs in humans.

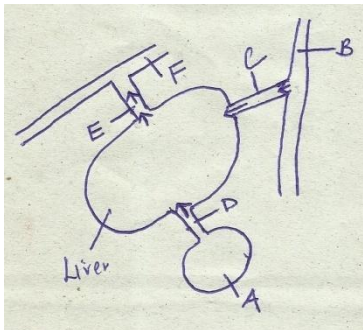

- a) Name the part labeled A
(1mk)

b) Name the blood vessels labeled B,D, E and F.
(4mks)

B E.....
D F.....

c) State how the composition of blood in vessel E differs from that in vessel D.
(3mks).

E D

d) Explain the role of bile in the process of digestion (2mks)

11. Below is a diagrammatic summary of the main biochemical events in photosynthesis. Study it carefully and answer the questions that follow.

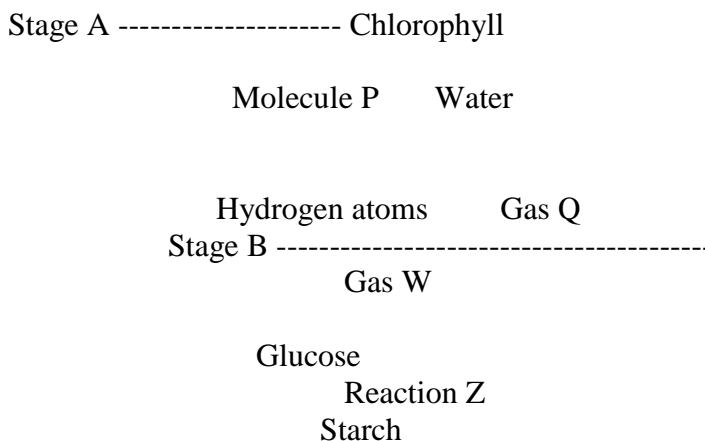

- a.
- i. Define photosynthesis (1mk)
 - ii. Name the stages A and B (2mks)

- iii. A..... B.....
Name the gases represented by the letters (2mks)
- Q..... W.....
b. Name the specific site for the reactions in stage A and B (2mks)
- A..... B.....
c. Name reaction Z.....
(1mk)
- d. What name is given in splitting water molecule into hydrogen atom and gas Q?
(1mk)
- e. Name one factor that affect the rate of photosynthesis
(1mk)

12. An experiment was set up as shown in the figure below.

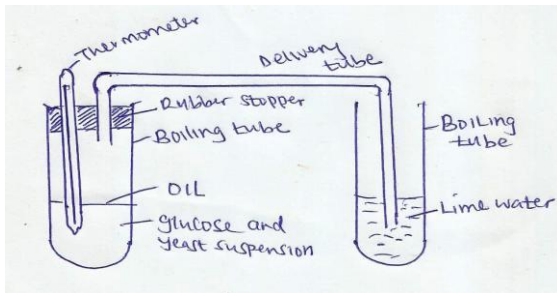

The glucose solution was boiled and cooled before adding yeast. The set up was left in stand for about 30 minutes.

- a. What changes occurred in the
- i) lime water (1mk)
 - ii) glucose and yeast? (2mks)
 - iii) Explain your answer in (a) above (3mks)

- iv) Name the process that was being investigated.
(1mk)
- v) What was the role of oil in the boiling tube?
(1mk)
- vi) Suggest control experiments for the above experiment.
(2mks)
- vii) Suggest the reason for boiling and cooling glucose before adding yeast.
(2mks)

13.

- a) Distinguish between heterodonts and homodonts.
(2mks)
- b) What is the significance of diastema in herbivorous mammals?
(1mk)
- c) State the role of carnassial teeth in a lion?
(1mk)
- d) An organism was found to have the dental formula:
$$\frac{0C \quad \quad P \quad \quad M}{0}$$
 - i. Calculate the total number of teeth in the organism
(1mk)
 - ii. With a reason suggest the mode of feeding of the organism from which dental formula was obtained.
(2mks)

For more Eresources Call: 0705 525657

- e) State one adaptation of the animals that uses the mode of feeding above.
(1mk)

SECTION C

14. Briefly describe the role of Osmosis in living organisms (10 mks)

15. Explain 5 factors affecting the rate of breathing in human beings. (10 mks)

mwalimuepublishers@gmail.com

FORM TWO SET 3 EXAMS 2020

NAME ----- INDEX NO-----
DATE _____ CANDIATES SIGNATURE _____

**BUSINESSTUDIES
FORM 2
TIME: 2 HRS**

For more Eresources Call: 0705 525657

1. Briefly define the following forms of utilities: (3

Mks)

i. Form utility.....

ii. Possession utility.....

iii. Place utility.....

2. Mutwiri has been advised by his bank to write a business plan. List four benefits Mutwiri will get by drawing a business plan. (4

Mks)

.....
.....
.....
.....

3. List four challenges faced by people as they seek to satisfy their wants (4 marks)

.....
.....
.....
.....

4. State three means of payment used in home trade. (3mks)

.....
.....
.....

5. Kenya has diverse unexploited natural resources that once exploited would propel Kenya into a developed nation. List four factors that limit Kenyan Government from exploiting these natural resources.

(4 marks)

.....
.....
.....
.....

6. SME sector has been attributed to entrepreneurial education in Kenya. Outline **four** contributions of entrepreneurs in Kenyan Economy. (4mks)

.....
.....
.....

7. Outline four differences between public corporation and public companies. (4 marks)

.....
.....
.....
.....
.....
.....
.....
.....

8. List four benefits consumers enjoy from warehousing (4 Mks)

.....
.....
.....
.....

9. Highlight four ways in which partners may be classified giving an example in each case.(4mks)

.....
.....
.....
.....

10. The Kenya government has diverse ways on controlling and regulating business in Kenya. Explain three ways that the Kenya Government regulates and control trade. (6 Mks)

.....
.....
.....
.....
.....
.....

11. There are various equipments used in offices, state the function of each of the following equipment in the office; (4 Mks)

i. Shreding machine

:.....
.....

ii. Composite machine

:.....
.....

iii. Duplicating machine

:.....
.....

iv. Franking machine

:.....
.....

12. Juma, Kipchoge and Murimi are deciding of forming a private limited company. Highlight three contents of the Articles of Association that they might consider (3 Mks)

.....
.....
.....

13. List four benefits of business studies to the Kenyan society. (4 Mks)

.....
.....
.....
.....

14. Containerisation is a common feature in road and water transport. List five benefits of containerisation. (5 Mks)

.....
.....
.....
.....
.....

15. Boda Boda (Motor Cycles) have emerged as the most common means of transport in rural Kenya, highlight four demerits of using this a means of transport (4 marks)

.....
.....
.....
.....

16. List and explain five components of effective communication . (5 Mks)

.....
.....
.....
.....
.....

17. Highlight four issues for consideration when selecting means of transport. (4 Mks)

.....
.....
.....

.....
18. Kenya Pipeline Company has been transporting petroleum products through the pipeline system to various parts of the country such as Sagana and Eldoret. List five benefits of this mode of transport. (5

Mks)

.....
.....
.....
.....
.....
.....

19. State four types of business activities carried out in Kenya. (4 Mks)

.....
.....
.....
.....

20. Murimi visited Kenya Commercial Bank Kerugoya and noticed that the manager's office was accessible to all since the bank had an open office policy. Outline four advantages of this type of office plan. (4

Mks)

.....
.....
.....
.....

21. Hawking is one of the simple forms of business in Kenya. List four disadvantages of Hawking business. (4 Mks)

.....
.....
.....
.....

22. Outline four emerging trends in office management. (4mks)

.....
.....
.....
.....

23. Highlight six services of a retailer (4 Mks)

.....
.....
.....
.....

24. Highlight four services offered in a warehouse (6 Mks)

.....
.....
.....
.....

FORM TWO SET 3 EXAMS 2020

NAME.....ADM NO.

ANSWER ALL THE QUESTIONS IN THE SPACES PROVIDED

1. Define the following:
a) Element (1mk)

b) Ion (1mk)

2. i) Identify the following apparatus and give a use for each (3mks)

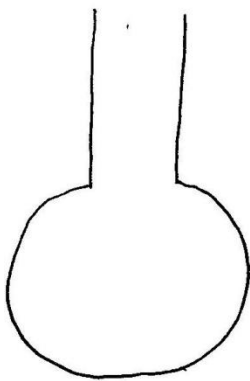

(a)

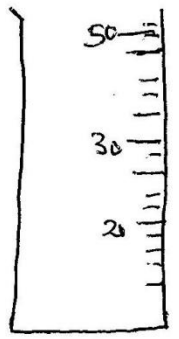

(b)

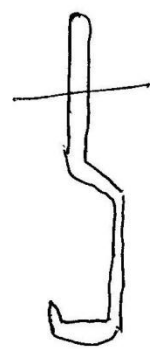

(c)

a)Use.....

b)Use.....

c)Use.....

ii) Name another apparatus that can be used in place of (b) (1mk)

3. Give four reasons why most apparatus are made of glass
(4mks)
4. Define the following terms
- a) Isotope (1mk)
- b) Ionization energy (1mk)
- c) Electron affinity (1mk)
5. Hydrogen gas was prepared in the lab. Using the following set up

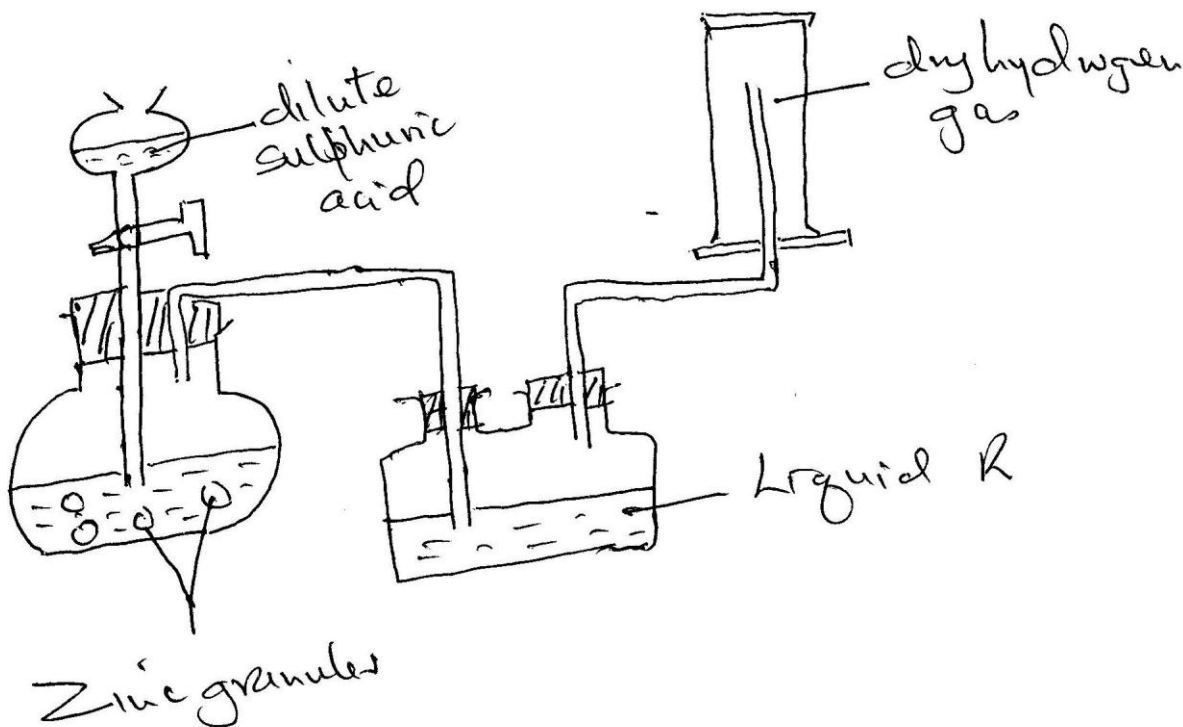

- a) Write an equation for the reaction taking place and balance it (2mks)

b) Name the method used to collect the gas and give a property of hydrogen that enables it to be collected through the method. (2mks)

c) Name liquid R and state its function in the set up (2mks)

Liquid R:

Function:.....

d) Explain why it is not advisable to use sodium metal in place of zinc metal (2mks)

e) State two uses of hydrogen gas (2mks)

f) What will happen to the pH of the solution in the beaker after one day? Give an explanation. (2mks)

6. Samples of urine from three participants F, G and H at an international sports meeting were spotted onto a chromatography paper alongside two from illegal drugs A1 and A2. A chromatogram was run using methanol. The figure below shows the chromatogram.

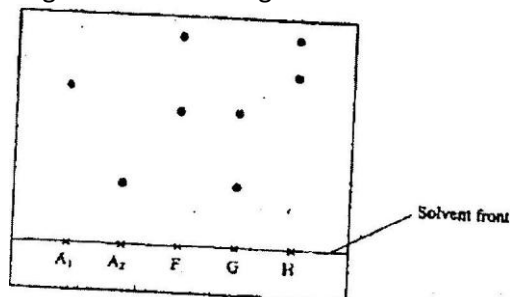

a) Identify the athlete who had used an illegal drug (1mk)

b) Which drug is more soluble in methanol?

(1mk)

7. The curve below represents the variation of temperature with time when pure and impure samples of a solid were heated separately.

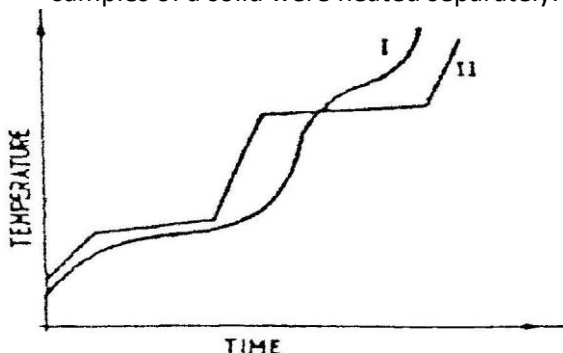

Which curve shows the variation in temperature for the pure solid? Explain.

(2mks)

8. In an experiment, a test-tube full of chlorine water was inverted in chlorine water as shown in the diagram below and the set up left in sunlight for one day.

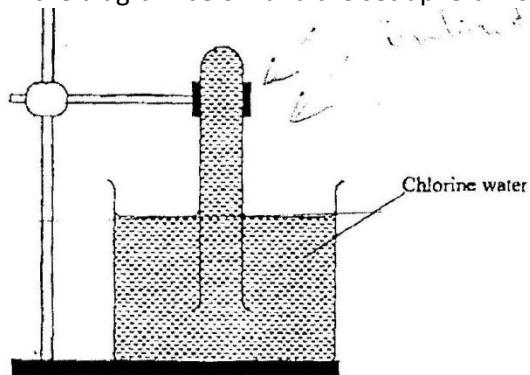

After one day, a gas was found to have collected in the test-tube

a) Identify the gas

(1mks)

b) How can the above gas be tested?

(2mks)

9. The table below shows some properties and electronic arrangements of common ions of elements represented by letters P to X. Study the information in the table and answer the questions that follow

Element	Electronic arrangement	Atomic radius	Ionic radius
	,8	97	99
		72	36
	,8	31	33
		43	50
	,8	33	74
		60	65
		86	95
		52	60
	,8	99	81

i.) Give the atomic numbers of the elements P and Q

(2mks)

P -

Q -

ii.) Select the most reactive metallic element

(1mk)

iii.) Select 3 elements that belong to the same group of periodic table
(2mks)

iv.) Select 3 elements that would react with cold water to evolve hydrogen gas (1mk)

v.) Why is the ionic radius of element X larger than its atomic radius? (1mk)

vi.) Write an equation of the reaction between element S and Oxygen (2mks)

10. Moist iron wool was inverted over water. The set up was left to stand for 2 days

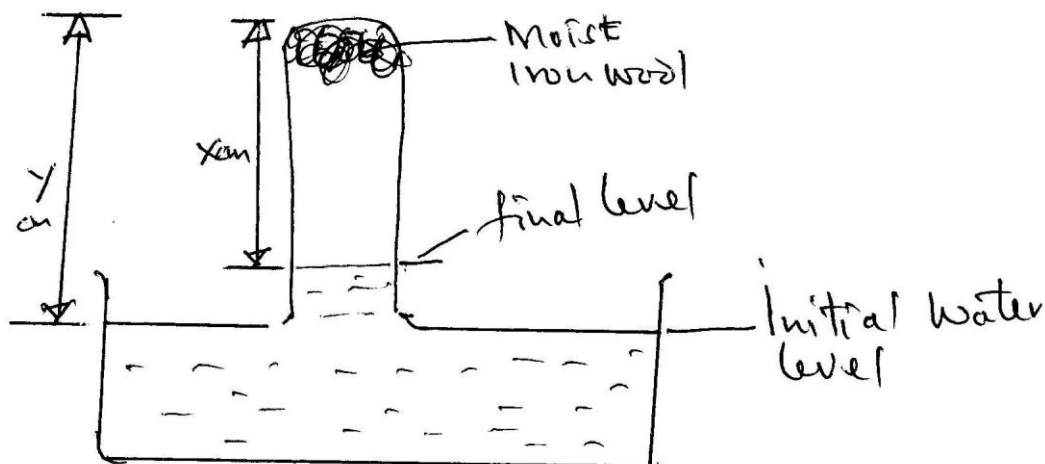

a) Explain whether rusting is a physical or chemical reaction (2mks)

b) Write an expression using X and Y to show the percentage of Oxygen (2mks)

c) What would be the effect of using a larger piece of iron wool? Explain. (2mks)

d) State two similarities between rusting and combustion (2mks)

11. Observe the equation below



i) Balance the equation (1mk)

ii) Select the following from the above equation
Oxidizing agent (1mk)

Reducing agent (1mk)

iii) State two situations where redox reactions are applied in industry (2mks)

12. Carbon (IV) sublimes at -78°C . It is called dry ice

a) Why is it called dry ice? (1mk)

b) It is used for keeping ice cream cold. Why is it preferred to ordinary ice? (2mks)

c) Name two other substances that behave as dry ice (2mks)

d) Give an industrial application of sublimation (1mk)

13. a) Element X has two isotopes. Two thirds of $^{33}_{16}\text{X}$ and one-third $^{30}_{16}\text{X}$. What is the relative mass of element X?

b) An element, A, has 30 protons and 35 neutrons. What is (2mks)
i) The mass number of element A?

ii) The charge on the most stable ion of element A?

c) An element B consists of three isotopes of mass, 28, 29 and 30 and percentage abundances of 92.2, 4.7 and 3.1 respectively. Show that the relative atomic mass of element is 28.11 (4mks)

d) Elements X and Y have atomic numbers 11 and 17 respectively. Which one of the elements is a metal? Give a reason for your answer. (2mks)

e) The table below shows the atomic numbers of four elements W,X,Y and Z

Element				
Atomic number				

two elements belong to the same group?

Which
(2mks)

- f) Two elements M and N have atomic numbers 17 and 20 respectively. Write the formula of the compound formed when M and N react.
(1mk)

14. The following diagram represents a non-luminous flame of the Bunsen burner

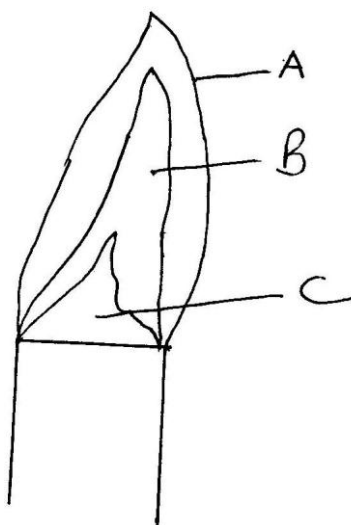

- a) Name the parts of the flame labeled A, B and C (3mks)
- b) Which of the parts in (a) above is the hottest? (1mk)
- c) A non-luminous flame is preferred for heating. Explain (2mks)
- d) i) Name the other type of flame produced by a Bunsen burner (1mk)

ii) Under what conditions does the Bunsen burner produce the flame in d(i)? (1mk)

e) Define the following terms as used in medicine

i) Drug (1mk)

ii) Prescription (1mk)

iii) Dosage (1mk)

iv) Drug abuse (1mk)

15. Balance the following chemical equations

i) $\text{Mg} + \text{O}_2 \rightarrow \text{MgO}$ (1mk)

ii) $\text{Mg} + \text{N}_2 \rightarrow \text{Mg}_3\text{N}_2$ (1mk)

iii) $\text{Al} + \text{HCl} \rightarrow \text{AlCl}_3 + \text{H}_2$ (1mk)

iv) $\text{C}_3\text{H}_8 + \text{O}_2 \rightarrow \text{CO}_2 + \text{H}_2\text{O}$ (1mk)

16. Hydrated Copper (II) Sulphate is heated in a boiling tube as shown.

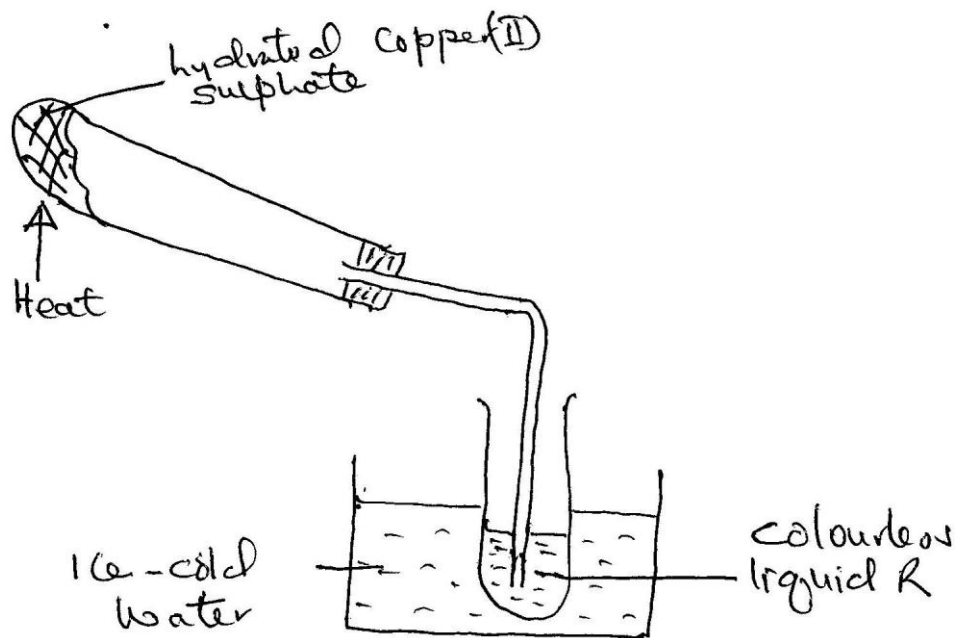

- i) State the colour of Copper (II) Sulphate before and after heating? (1mk)

- ii) Explain why the boiling tube was slanted (1mk)

- iii) How can the purity of the colourless liquid be confirmed? (1mk)

- iv) Name another substance that can undergo the same change as hydrated Copper (II) Sulphate (1mk)

17. A Magnesium ribbon was cleaned with steel wool and used in the following set up. Wet sand was heated before Magnesium ribbon.

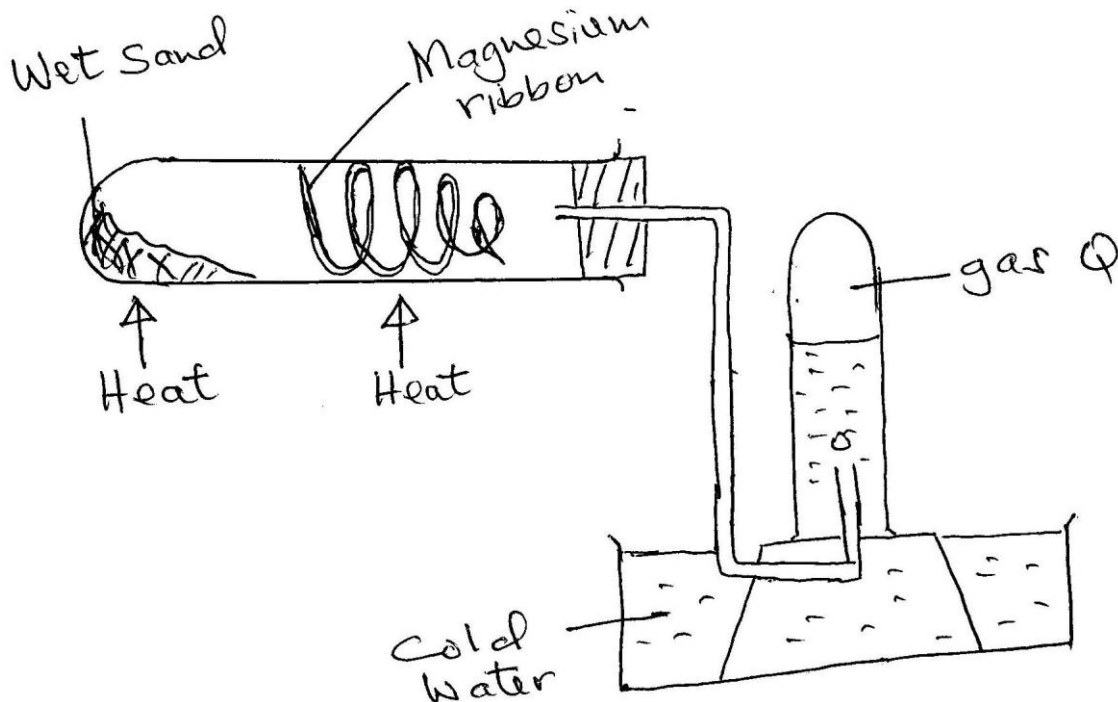

- a) Explain the following:
- i) Sand was heated first before heating Magnesium ribbon (1mk)

 - ii) Magnesium ribbon was cleaned with steel wool (1mk)
- b) Name gas R (1mk)
- c) Write an equation for the reaction taking place in the combustion tube (1mk)
- d) Name the method used to collect gas R (1mk)

FORM TWO SET 3 EXAMS 2020

C.R.E. FORM 2

NAME..... ADM CLASS

1(a) Give reasons why the Bible is referred to as a library (5mks)

(b) Explain five effects of the translation of the Bible into local languages. (10mks)

(c) State five ways in which the church is spreading the word of God in Kenya today (5mks)

- 2(a) State six promises that God made to Abraham (6mks)
- (b) Outline the activities carried out by the Israelites on the night of the Passover (6mks)
- (c) What problems did Moses face as he led the Israelites during the exodus?(8mks)
- 3(a) Identify seven ways which show that King Solomon turned away from the covenant way of life. (7mks)

(b) Outline rituals performed during the birth of a baby in traditional African Communities. (7mks)

(c) Name six places in which sacrifices are carried out in Traditional African Communities (6mks)

4(a) Outline Micah's prophecy about the Messiah (Micah 5: 1 – 5) (6mks)

(a) State six activities that took place when Jesus was born (Luke 2: 6 – 20) (6mks)

(c) Explain what the magnificat reveals about the nature of God. (8mks)

5(a) Outline the instructions that Jesus gave to the seventy two disciples when he sent them on a mission. (8mks)

(b) Relate the parable of the praying Pharisee and the tax collector (5mks)

(c) Give reasons that make Christians pray (7mks).

FORM TWO SET 3 EXAMS 2020

FORM 2 ENGLISH

NAME: ADM NO :

This paper consists of six Sections as follows;

SECTION A: WRITING	20mks
SECTION B: COMPREHENSION	20mks
SECTION C: CLOZE TEST	10mks
SECTION D: ORAL SKILLS	15mks
SECTION E: LITERARY APPRECIATION	20mks
SECTION F: GRAMMAR	15mks
TOTAL	100MKS

INSTRUCTIONS :

- 1. Answer ALL questions in the spaces provided.*
- 2. Use of ungrammatical constructions will be penalized*
- 3. Observe punctuation and correct use of capital letters.*

All the best

SECTION A : WRITING (20mks)

1. You attended a cousin’s wedding during the April holiday. On the day of wedding, your younger sister Celestine Wanjiku went missing. You decided to help your parents in the search for the girl, hence, you did not open school with the rest, which is against the school rules.

Write a letter of Apology to the Principal of your school, explaining what made you not report on the first day of the term.

.....

.....

.....

.....

.....

.....

.....

.....

.....

.....

.....

.....

.....

.....

.....

.....

.....

.....

.....

.....

.....

.....

SECTION B: COMPREHENSION

(20mks)

Read the passage below and answer the questions that follow

Decades ago, two geologists visited Migori County and left villagers with high hopes of striking it rich.

A valuable mineral had been discovered.

Now, 20 years later, nothing much has been done to tap the gold in Macalder. Instead, hundreds of people have died in the process of digging the mines, while pregnant women working in the area have been giving birth to children with deformities.

Residents attribute their misfortunes to lack of modern equipment to professionally exploit the mineral. They have been mining gold using mercury mixed with water and powdered stones which they stir to the consistency of porridge before washing off the mercury into their farms.

One man is keen to prevent deaths among the residents depending on gold mining as a source of income.

He has invented a gold mining machine- the ball mill machine.

Mr. Olello, 41 says he got idea for the machine from a friend who went to Zimbabwe on business and returned with a photograph of a gold mining machine.

“It took me two years to design my first machine and in 1999, I eventually came up with the ball mill” . Mr.Okello says his villagers neither knew nor cared whether mercury was harmful to their health.

Mr. Okello explains that his machine is a multipurpose appliance. It can mill numerous kinds of rocks for building materials industry.

For gold mining, the machine uses small steel ball grinders which separate gold ore from dust, after which it is further refined.

Among the places that have been mapped for gold deposits within the region are Rongo, Kehancha in Kuria District; Masara and Kehara in Nyatike constituency, Lolgorian area in Trans Mara and some parts of Siaya county.

Gold qualities make it one of the most coveted metals in the world. Not only can it be beautifully shaped and sculpted, the yellow metal conducts electricity and does not tarnish.

Gold has been used in dentistry for nearly 3,000 years. It is used for filling, crowns, bridges and orthodontic appliances. Gold can be placed in contact with person's body and not cause harm.

QUESTIONS

- a) What gave the villagers the hopes of striking it rich?
(2mks)

- b) Outline the challenges experienced by the villagers in the mines.
(2mks)

- c) What according to the residents contribute to their misfortunes?
(2mks)

- d) Explain how the rate of deaths among the villagers has been prevented.
(2mks)

- e) How did Mr. Okello get the idea of the machine?
(2mks)

- f) "It took me two years to design my first machine and in 1999 I eventually came up with the ball mill," says Mr. Okello. (Rewrite in reported speech)
(2mks)

- g) Mr. Okello explains that the machine is a multipurpose appliance (add a question tag)
(1mk)

- h) Make notes on uses of gold
(4mks)

i) State the meaning of the following words as used in the passage

(3mks)

i. Invented –

ii. Mapped –

iii. Coveted-

SECTION C: CLOZE TEST

(10mks)

Fill in the blank spaces with the most appropriate word.

What is good governance? This is a question that people 1 very often. It refers to the responsible 2 of the affairs of a village, town or country.

Where there is good governance, people live in harmony; ways of 3 poverty are sought and people assume ownership 4 the process of developing their communities.

5 the government is expected to create a 6 political and legal environment for development, it cannot succeed if ordinary citizens do not cooperate and play their role. Everyone craves for the 7 of the rule of law, but if we do not obey that 8 law, we will not know peace. We accuse certain sectors of 9 but give bribes in order to induce others to give us 10 treatment. If we really desire to have positive changes in our society, we must change our attitude and join our hands in building a society.

SECTION D: ORAL SKILLS

(15mks)

I. *Read the narrative below and answer the questions that follow.*

One day the chameleon and the donkey were arguing as who could run faster than the other.

The donkey said; "You chameleon, you are very old. You can't compete with me in a race."

For more Eresources Call: 0705 525657

The chameleon replied, “Don’t blow your own trumpet. I am not going to praise myself but I know you can’t defeat me in a race. We shall be equal.”

The race began and the chameleon jumped on the donkey’s tail. They ran until the donkey was so tired that he stopped to rest. As soon as the donkey stopped, the chameleon jumped from the donkey’s tail and said, “Now my friend donkey, are you faster than I?”

“No, now I know that you are a man.”

Questions

a) Mention any **two** things you would do to capture the attention of the audience before you begin your narration.

(2mks)

b) Explain any **two** ways you would use to make the narration from, “The chameleon replied.....(line 4) ...We shall be equal. (line 5) effective.

(2mks)

c) If you were part of the audience for this story, explain three things you would do to show that you are participating in the performance.

(3mks)

II. In each of the following words, underline the syllable that is stressed.

(4mks)

a) chal .lenge (verb)

b) ad.vise

c) ac.cent(noun)

d) de.lete

III. For each of the following words, write a word that is pronounced the same way

(4mks)

a) time

b) toad

c) what

d) seller

SECTION E: LITERARY APPRECIATION (20mks)

Read the song below and answer the questions that follow.

Daughter of Lekamoi

Oh, mother
Behold the daughter of Lekamoi
Who has just grown up
Young woman, when will she return
When does my love come back?
Daughter of the bull?
Woman, come, let me see you,
Listen;
Daughter of Lekamoi
Leader of the girls
When does my own arrive?
Ah! Abul, chief of women.
Her neck resembles a snake
Coming out of a vase
Behold, daughter of Lekamoi

Her teeth are like ash
Oh, when does my love come back?
Daughter of the bull
Abul, come and dance before me
Listen
Daughter of Lekamoi
Who has just shot up,
All men want her
Ah, Abul, chief of women

For more Eresources Call: 0705 525657

My girl appears on the path from
Anaka
Behold the daughter of Lekamoi
Tall and graceful
With whose daughter can you
Compare her?
My companion, when will
She return?
Daughter of the bull
Woman come, I will take
You from your husband, Listen
Daughter of Lekamoi,
Leader of the girls,
Ye, all the men want her
Abul,Chief of women.

Questions

- i. What type of song is this? Give reasons for your answer. (2mks)

- ii. who is the singer? (1mk)

- iii. To whom is the song sung? (1mk)

- iv. Describe the singer's attitude towards the subject? (3mks)

- v. Where is Abul at the time of singing?
(2mks)

- vi. What makes the song an **oral** song? Support your answer
(4mks)
- vii. Identify and illustrate any **two** poetic styles used in this song
(4mks)
- viii. With illustrations, describe the mood of the song? (3mks)

SECTION F: GRAMMAR

(15mks)

I. Fill in the blank spaces with the correct preposition.

(4mks)

- a) Every member was asked to part _____ twenty shillings for the purchase of the gift.
- b) He bought a bicycle _____ loan from the credit shop in town.
- c) We heard the news _____ the radio.
- d) Have a look of yourself _____ the mirror.

II. Fill in the blank spaces using the correct form of the verb in the blanket

(4mks)

- a) If I had the money, I _____ (buy) the computer already.
- b) If I _____ (be) Bill Cosby, I would have helped the poor with the money I made.

For more Eresources Call: 0705 525657

- c) We _____(walk) along Koinange street when we met him.
d) The party _____(start) when we arrived.

III. Rewrite each of the following sentences as instructed.

(5mks)

- a) Wanjohi is more responsible than his brother.

Wanjohi is the last born.

Join the two sentences, beginning with the word 'although'

- b) The man bombed the hotel.

He was finally arrested.

Join the two sentences, using the word 'who'

- c) Jane is strong. Her brother is equally strong.

Join the two sentences using a comparative

- d) The young man was very hungry. He swallowed the potato without chewing it.

Join the two sentences beginning with 'so'

- (e) Kimani said, "I will do the work tomorrow"

Rewrite in reported speech

IV. Arrange the adjectives in brackets and use them to fill in the blank spaces.

- a) The East African community has

_____forces. (Combined, military,
powerful).

- b) She bought a _____ bed.

(huge, wooden, old, Japanese)

mwalimuepublishers@gmail.com

FORM TWO SET 3 EXAMS 2020

NAME..... ADM NO..... DATE.....

GEOGRAPHY:312

FORM TWO

TIME: 2 HOURS

INSTRUCTION TO STUDENTS

Write your name and admission number in the spaces provided above.

Attempt all questions

All your answers must be written in the spaces provided below each question.

For more Eresources Call: 0705 525657

a) Define Geography (1mk)

.....
.....

b) Draw a well labeled diagram to show the centrality of geography
(4mks)

2. a) Give two reasons for the shape of the Earth (2mks)

b) State three characteristics of sedimentary rocks
(3mks)

3. a) What is the longitude of city Y whose local time is 8.00am, when the local time at green which meridian 0° is 12.00 noon? (2mks)

b) Give three characteristics of the Inner core of the earth
(3mks)

4. (a). (i) Differentiate between faulting and folding.
(2mks)

(ii) Draw a well labeled diagram to show the parts of a normal fault.
(5mks)

(b) (i) Describes the formation of Rift Valley by tensional forces by
use of well labeled diagram.

(7 marks)

(ii) Explain three significance of vulcanicity to Human activities. (6mks)

5a (i) differentiate between weather and climate. (2mks)

(ii) Explain four factors that influence climate. (8mks)

b) Explain two effects of climate change on the physical environment. (4mks)

6. Study the map of Kitale provided below and answer the questions that follow:-

- a) i) Convert the linear scale on the map into a representative fraction (show your working) (3mks)

For more Eresources Call: 0705 525657

ii) Name the districts covered in the map
(3mks)

iii) Calculate the area covered by Kitale township (2mks)

b) i) What is ITCZ? (2mks)

ii) State four characteristics of the Equatorial climate
(4mks)

c) You are to carry out a field study in the Rift Valley
i) Outline your preparation (4mks)

ii) What three other fault features would you study besides the rift valley.
(3mks)

iii) State one hypothesis of your study (1mk)

iv) Give three follow up activities you would carry out
(3mks)

7. a (i) Differentiate between direction and bearing.
(2mks)

ii) State two traditional methods used to show direction on maps.
(2mks)

b (i) Explain four uses of maps.
(4mks)

(ii) State three marginal information a good map must have.
(3mks)

c) List three ways used to locate places on a map.
(3mks)

8 a (i) Define photograph.
(2mks)

iii) State 3 types of ground photographs.
(3mks)

b (i) List three types of graphs used for statistical presentation.
(3mks)

(ii) Explain two advantages of comparative line graph.
(2mks)

iii) Explain two disadvantages of a comparative bar graph.
(2mks)

FORM TWO SET 3 EXAMS 2020

HISTORY FORM 2

NAME.....CLASS.....ADM.....

INSTRUCTIONS: ANSWER ALL QUESTIONS

II) YOU MUST WRITE LEGIBLY

SECTION A(25MKS)

1. Name the branch of history that deals with the study of people's way of life. (1mk)
2. List down three aspects of history. (1mk)
3. Identify any two forms of oral traditions which can be used as a source of information on history and government. (2mks)
4. Give two reasons why early human beings lived in groups. (2mks)
5. List down two theories that attempt to explain the discovery of agriculture by man. (2mks)
6. Identify two groups of Cushitic speakers who migrated to Kenya. (2mks)
7. What was the main importance of age-set system among the Kenyan communities? (1mk)
8. Give four reasons for the coming of Portuguese to East Africa Coast in the 15th Century. (4mks)
9. Give the main reason for the coming of the Christian missionaries to E. Africa. (1mk)

For more Eresources Call: 0705 525657

10. Name three continents that participated in the Trans-Atlantic Slave Trade. (3mks)

11. Give one contribution of George Stephenson on transport. (1mk)

12. Name three early sources of energy. (3mks)

13. Name the person who invented the following. (2mks)

i) Electricity

ii) Telephone

SECTION B (75MKS)

14. a) Identify five levels of conflict. (5mks)

b) Identify five peaceful methods of resolving conflict. (5mks)

15.a) What do you understand by the following words/phrases

i) Third World countries. (1mk)

ii) Neolithic period. (1 mk)

ii) Agrarian Revolution. (1mk)

b) Explain four effects of early agriculture on man. (8mks)

16.a) Name three communities in Kenya that took part in the long distance trade. (3mks)

b) List down five challenges that were faced by traders during the Trans-Saharan Trade. (5mks)

17.a) State five disadvantages of animal transport. (5mks)

b) Explain five impacts of road transport in Kenya. (10mks)

18.a) State five uses of gold during thee ancient times. (5mks)

b) List down five factors that facilitated the spread of iron working in Africa. (5mks)

mwalimuepublishers@gmail.com

19.a) Identify four sources of energy during the Industrial Revolution in Europe. (4mks)

b) Explain five factors that facilitated the development of industries in Britain. (10mks)

20. State five effects of the scientific Revolution on agricultural factor. (5mks)

For more Eresources Call: 0705 525657

FORM TWO SET 3 EXAMS 2020

Jina.....Darasa:.....Nambari:...

**KISWAHILI
KIDATO CHA PILI**

MAAGIZO

Jibu maswali yote.

1. UFAHAMU

Soma makala yafuatayo kisha ujibu maswali.

Changamoto kubwa inayowakabili watu wengi katika mataifa yanayoendelea ni suala la chakula. Suala hili linaweza kuangaliwa katika sawia mbili tofauti. Kuna tatizo linalofungamana na uhaba wa chakula chenyewe. Uhaba huu unaweza kutokana na utegemezi mkubwa kwa zaraa kama nyenzo kuu ya uzalishaji wa chakula.

Zaraa katika mataifa mengi hususan yanayoendelea, hutegemea mvua. Kupatikana kwa mvua huathiriwa na mabadiliko ya tabianchi ulimwnguni. Matendo na amali za watu kama ukataji wa miti na uchafuzi wa mazingira huwa na athari hasi kwenye tabianchi hiyo. Mabadiliko ya tabianchi huweza kuvyaza ukama kutokana na **ngambi ya mvua**.

Kibinimethali kutokea wakati mafuriko yanapotokea na labda kuyasomba mazao mashambani na kusababisha baa la njaa. Hali hizi mbili husababisha matatizo makubwa ya chakula na kuathiri pakubwa suala zima la usalama wa chakula. Ili kuzuia uwezokano wa kuwepo kwa shida hii, pana haja ya kuwepo kwa mikakati na sera za kuhakikisha kuna usalama wa chakula. Kwa mfano, pana haja ya kukuza kilimo cha umwagiliaji ili kuepuka **adha** inayosababishwa na ukosefu wa mvua. Kwa upande mwingine, sharti zichukuliwe hatua mufidi za kuzuia na kupambana na athari za gharika.

Changamoto nyingine inahusiana na usalama wa chakula chenyewe. Chakula kilichosibikwa na vijasumu au kwa njia nyingine ile huweza kumdhuru anayehusika. Msibiko wa chakula unatokana na vyanzo tofauti. Mathalan uandalizi wa chakula kilichochofuliwa na choo, kutozingatia mbeko za usafi, uandaaji wa chakula na kukiweka katika hali ya uvuguvugu kabla ya kukipakua – hali inayochochea ukuaji wa viini na ulaji wa chakula kisichoandaliwa vyema.

Ili kuepuka uwezekano wa kuathirika, pana haja ya kuzingatia usafi wa chakula na uandalizi unaofaa. Fauka ya hayo, vyombo cya uandalizi view safi,

kanuni za usafi zifuatwe, upikaji na uandaaji uwe kamilifu. Hali hii isipozingatiwa, siha za raia wenyewe zitaathirika pakubwa.

Maswali.

1. Taja aina mbili za kuangalia suala la chakula katika mataifa yanayoendelea.

(alama 2)

2. Taja hatua mbili zinazoweza kuchukuliwa kupambana na tatizo la chakula.

(alama 2)

3. Eleza jinsi nne tofauti namna chakula kinavyoweza kuwa si salama?

(alama 4)

4. Kwa nini ni rahisi kukipakua chakula baada ya kukiandaa tu?(alama 1)

5. Ni mapendekezo gani anayoyatoa mwandishi kuhakikisha kuwa chakula kinafaa?

(alama 4)

MATUMIZI YA LUGHA

1. Kwa kutoa mifano eleza tofauti kati ya:

(alama 2)

i. Silabi funge

ii. Silabi wazi

2. Onyesha sauti zenye sifa zifuatazo:

(alama 2)

i. Kipasuo cha ufizi

ii. Kikwamizo cha kaaka laini

3. Tambua aina ya nomino katika sentensi zifuatazo.

(alama 2)

i. Mchanga hufanya miti kumea.

4. Bainisha mofimu katika kitenzi.

(alama 2)

Kilipikika

5. Tambua vivumishi katika sentensi ifuatayo na ueleze ni vya aina gani.

(alama 2)

i. Mtoto wake ameng'oka jino.

ii. Msemo wenye tafsida hupendwa.

For more Eresources Call: 0705 525657

6. Andika kinyume cha:

(alama 1)

Tulinunua nguo aliizozianika jana.

7. Nomino 'uki' iko kwenye ngeli gani.

(alama 1)

8. Ainisha vitenzi kwenye fungo zifuatazo:

(alama 3)

i. Yatakuwa yangali yanakoma.

ii. Maria na Atieno ni wanafunzi watiifu.

9. Onyesha vielezi katika sentensi zifuatazo.

(alama 2)

i. Rais ametutembelea mara sita mwaka huu.

ii. Nendeni haraka shuleni.

10. Eleza maana inayojitokeza kwenye sentensi ifuatayo.

(alama 1)

i. Waiteni watu wale.

11. Tumia kiwakilishi kisisitizi kutungia sentensi ya wingi wakati uliopita.

(alama 2)

ISIMU JAMII

Soma makala yafuatayo kisha ujibu maswali.

Haya ng'ara ... Ng'ara leo! Nguo motomoto. Ng'ara leo kwa bei rahisi. Hamsini hamsini shati. Kuona ni bure. Bure kwa bure. Shika mwenyewe ujionee. Bei nafuu. Bei ya starehe. Haya, haya. Usikose mwanangu! Hamsa! Hamsa! Fifty!Hamsa! Fifty! Hamsa na nyingine.

Maswali.

a. Bainisha sajili ya mazungumzo haya.

(alama 1)

b. Eleza sifa nane za sajili hii kwa kurejelea kifungu hiki.

(alama 4)

FASIHI SIMULIZI.

a. Fafanua maigizo.

(alama 2)

b. Ainisha kipera cha maigizo.

(alama 4)

c. Eleza sifa za maigizo.

(alama 4)

FORM TWO SET 3 EXAMS 2020

PHYSICS FORM TWO

NAME:ADM NO:CLASS:

INSTRUCTIONS.

1. Answer all questions in the spaces provided below.

1. Define the following terms giving appropriate examples. (4mks)

a) Magnetic materials-

b) Non-magnetic materials-

2. 0.01cm^3 of oil spreads out on water to form a patch of diameter 28cm. estimate the diameter of an oil molecule ,and express your answer correct to 3s.f.g. (3mks)

3. A uniform meter rule with a mass of 200g suspended at zero mark is pivoted at the 22.0cm mark. Calculate the mass of the rule. (4mks)

4. State **three** uses of magnets. (3mks)

5. Explain the following. (4mks)

a) Principal of moments of a force.

b) Moment of a force is a vector quantity.

6. The micrometer screw gauge below has a zero error of -0.15.Determine the final Redading of the instrument. (3mks)

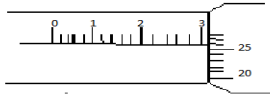

7. State **two** factors that affect the centre of gravity. Explain each briefly. (4mks)

8. State **two** practical applications of the C.O.G. (2mks)

9. A solid weighs 36N on the Moon. The force due to gravity on the moon is 1.7N/Kg. Determine the mass of the solid. (3mks)

10. Use simple sketches of a cone to illustrate the three states of Equilibrium. (3mks)

11.a) Give a reason why water is not suitable as a barometric liquid. (2mks)

b) Explain the application of 11(a) above. (1mk)

12. Determine the density in SI units of a solid whose mass is 40g measuring 30cm long, 4cm wide and 3cm thick. (4mks)

14.a). Sketch **two** diagrams of a wire loop dipped in soap solution to illustrate the surface tension experiment. (2mks)

For more Eresources Call: 0705 525657

b) Explain the observation in 14 (a) above. (2mks)

15. A uniform wooden bar of length 1m and mass 5kg is pivoted at 40cm mark as shown below.

Calculate the value of F_1 . (4mks)

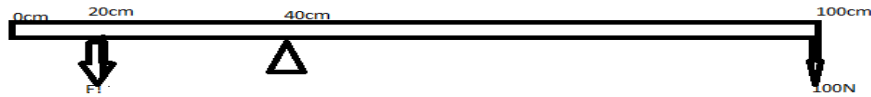

16. Using domain theory of magnetism, explain how a magnet may lose its magnetism on heating and hammering. (4mks)

17. Distinguish between soft and hard magnetic materials. (2mks)

18. A boy jumping from a high table tends to spread his legs. Explain (1mk)

19. State **two** differences between mass and weight. (2mks)

20. State **two** practical applications of friction. (2mks)

21. What is wrong with the statement. "the mass of an astronaut in the moon is $1/6^{\text{th}}$ his mass on earth". (1mk)

22. State the **two** conditions for a body to be in equilibrium. (2mks)

For more Resources Call: 0705 525657

23. Explain what is meant by magnetic shielding and state one application of magnetic shielding. (2mks)

24.a) Define the following terms. (2mks)

i) Principal focus-

ii) Radius of curvature-

25. An object is placed 30cm from a concave mirror of focal length 20cm. Calculate. i) The image position (2mks)

ii) The magnification (2mks)

26. State **one** advantage and one disadvantage of using a convex mirror. (2mks)